



## Airsock unit coolers THOR-A

Standard coolers with Cu tubing





## Contents

	page
Model indication .....	2
Eurovent .....	2
Capacities .....	2
General information .....	3
Standard product configuration .....	3
Non standard executions .....	4
Correction factors & Selection example .....	5
Capacities & technical data .....	6
Fans .....	10
Defrost systems .....	11
Dimensions .....	12

## Model indication

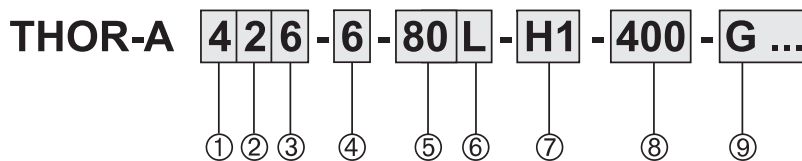

Pos.	Reference	Options
1	Cooler module	1 - 4
2	Number of fans	1 - 3
3	Tube rows	4 or 6 tube rows in air direction
4	Fin spacing	4, 6 and 7 mm
5	Ext. pressure	40, 60, 80, 100, 120 Pa
6	Fan speed	L, H (1000/1500 rpm)
7	Circuiting design	2H, H1, H2 ...
8	Current	400 = 230/400/50/3 230 = 230/50/1
9	Options	For a full survey of all available options see page 4

## Eurovent

Within Europe, a wide variety of published data on capacities are in use, generally depending on national standards. Most in use by the leading manufacturers are national and international standards like DIN, ENV, NEN-EN and ASHRAE.

Due to this, customers have not been able to make objective product comparisons, since data published on capacities were based on  $DT_1$ , DTM, dry or wet conditions, with or without certification, etc.

To meet the European requirements on EN standards, the European Refrigeration Industry embodied by Eurovent has set standards to guarantee an independent certification procedure for forced convection air cooled condensers based on NEN-EN 327 and unit air coolers based on NEN-EN 328. Being an active member of Eurovent, the capacities of the Alfa Laval commercial cooler programme, as given in the technical documentation, are based on NEN-EN 328 (evaporating temperature  $t_0 = -8\text{ }^\circ\text{C}$ , 8 K temperature difference between air-on temperature and evaporating temperature ( $DT_1$ )).

In order to enable air cooler selection for operating conditions, technical documentation should also give capacities for humid/frosted conditions. According to Eurovent these 'frosted conditions' are to be calculated by multiplying 'dry capacities' with a factor 1.15. These data can be found in the capacity tables, in the columns marked "frosted".

## Capacities

## Frosted conditions

- Lightly frosted coil.
- Relative humidity 85 %.
- Suction gas superheating 62% of the temperature difference ( $DT_1$ ), with a minimum of 3.5 K.
- Refrigerant liquid temperature 30 °C

Evaporating temperature  $t_0$ 

Evaporating temperature  $t_0$  is the saturated temperature according to the pressure at the suction outlet of the cooler.

## Dry conditions

Cooling capacity where no condensation or ice build-up occurs on the coil (100% sensible cooling). This condition is used by Eurovent to standardise capacity ratings but should not be used when selecting coolers. For cooler selection use the columns marked "frosted".





### General Information

For air sock application Alfa Laval has developed a special air sock cooler range. These THOR-A coolers are fitted with an airsock ring and fan motors capable of supplying the extra external pressure that is required for the proper functioning of airsocks. THOR-A ranges to 78 models with 1 to 3 fans. Application area: evaporating temperatures of +5 down to -15 °C using either halogen refrigerants, CO<sub>2</sub> or secondary refrigerants.

Capacities (Eurovent SC 2) 4 up to 46 kW.

Air sock diameters 450 up to 730 mm.

### Air sock selection

For a correct selection and dimensioning of air sock systems to be used in combination with THOR-A coolers, you will have to consult your air sock supplier.

### Other THOR models

#### THOR

The THOR series is a wide and flexible range of industrial air coolers fitted with blow-through or draw-through fans. These models have been highly standardised in construction and dimensions, while maintaining flexibility in fin spacings, coil construction and circuiting design.

#### THOR-D

Low silhouette dual discharge air coolers.

#### THOR-F

Air cooler models THOR-F have been optimized for the refrigerated storage of agricultural products. These cooler models are characterised by an optimised capacity / air volume ratio and a relatively low profile.

All THOR, THOR-D, THOR-F and THOR-A models are also available with stainless steel tubing (TYR range).

### Two-Year Guarantee

Because Alfa Laval has the fullest confidence in the product quality, a two-year full guarantee is given.

### Product Configuration

- Finned coil
  - 4 coil block modules
  - 4 or 6 tube rows deep
  - Cu ripple fin tubing  $\varnothing$  5/8" (smooth tubing for brine)
  - Tube pitch 50 x 50 mm square
  - Corrugated Alu-fins
  - Fin spacings 4, 6 and 7 mm.
- 1-3 Fans, drawing through the coil, available in a range of different executions.
  - Air sock diameters  $\varnothing$  450 mm up to  $\varnothing$  730 mm.
  - Fan motors protection class IP55.

- Corrosion resistant casing material:
  - Aluminium/Sendzimir, white epoxy coated (RAL 9003).

- Hinged, enclosed endcovers.

- Hinged driptray.
  - Drain(s) 32 mm PVC connection, freely adjustable into either horizontal or vertical position.

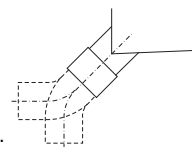

- Refrigerant distribution optimised to refrigerant applied.
- Refrigerant connections on right hand side (fan side view)
- Fitted with schrader valve on the suction connection for testing purposes.
- Sufficient room for fitting the expansion valve inside.
- Suitable for dry expansion or pumped system.
- Stickers indicate fan direction and refrigerant in/out.
- Delivery in mounting position. Coolers are mounted on wooden beams. Installation can take place with use of a forklift.
- Design pressure 33 bar (H(C)FC) or 6 bar (brine). Higher design pressures on request. Each heat exchanger is leak tested with dry air and finally supplied with a nitrogen pre-charge.





## Options

**■ Defrost systems**

- Hot gas coil in driptray
- Electric defrost
- Water defrost

**G1**  
**E1, E4**  
**W**

*Electric defrost for air coolers with pumped refrigerant circulation or in glycol execution on special request only.*

**■ Driptray insulation**

- Styropore 10 mm + cladding **I 2**  
*not in combination with electric defrost*
- Foamglass 25 mm + cladding **I 3**

**■ Refrigerant connections**

Left hand side, fan side view **L**

**■ Mounting feet**

*For floor mounting, coolers can be equipped with hot dip galvanized steel mounting feet. The positioning of these is the same as the suspension brackets for ceiling mounting.* **MF**

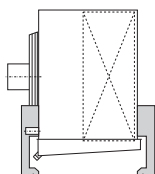
**■ Isolating switch (mounted)**

**ISM**

**■ Secondary refrigerant**

*Air coolers for secondary refrigerant application can be selected with our selection software. Extra information on request.*

**■ Stainless steel 304 casing**

**SSC**

**■ Suction hood**

**SH**

**■ Fan motors 400/60/3 or 230/60/1**
Non-standard executions *(on request only)*
**■ Higher capacities**
**■ Special fan motors:**

- Dual fan speed motors
- Variable fan speed motors
- EC fans
- Alternative electrical supply 460/60/3

**■ Built in heater coil sections**

## Driptray Insulation ( I )

For specific operational conditions the air coolers can be fitted with driptray insulation.

Insulation of the driptray is recommended for air coolers with hot gas defrosting used at a room temperature below -5 °C. For areas with high relative humidity it may also be necessary to insulate other parts of the casing.

At extra cost this driptray insulation can be combined with the usual epoxy coating.

*Note : When selecting driptray insulation the overall height "B" of the coolers (see page 12) increases by the thickness of the insulation material applied.*

Selection Example DT<sub>1</sub>

Refrigerant	R-404A dx
Selected fin spacing	6 or 7 mm
Required external pressure	80 Pa
Fan speed	1500 rpm
Required cooling capacity	15 kW
Air-on temperature	+6 °C
Evaporating temperature	0 °C

- 1)  $DT_1 = +6 - 0 = 6$  K
- 2) Correction factor  $DT_1 / R-404A : 1.28$
- 3) Multiply required capacity with correction factor :  $15 \times 1.28 = 19.2$  kW.
- 4) Cooler models can be selected in columns 'capacity / ext. press. 80 Pa' on page 8 with a nominal capacity of 19.2 kW.

For the above mentioned conditions the following models can be selected :

- THOR-A 324-6, nom.cap. 18.3 kW.
- THOR-A 326-6, nom.cap. 24.4 kW.
- THOR-A 424-6, nom.cap. 22.3 kW.
- THOR-A 424-7, nom.cap. 20.9 kW.

Depending on parameters such as *air flow*, *number of fans* and *dimensions* (see tables) a final cooler model selection can take place.

Capacity values as given in the tables are nominal capacities.

Standard condition SC	Air on temp. °C	Evaporating temperature °C	Factor dry/frosted
SC1	10	0	1.35
SC2	0	-8	1.15
SC3	-18	-25	1.05
SC4	-25	-31	1.01

SC 2 : Nominal capacity for cooling design.

Air-on temperature is the air temperature at the intake side of the coil block.

## Correction factors

DT <sub>1</sub> K	Evaporating temperature °C				
	+5	0	-5	-8	-10
<b>R-404A dx</b>					
6	1.22	1.28	1.33		1.38
7	1.02	1.07	1.13		1.18
8	0.87	0.92	0.97	<b>1.00</b>	1.03
9	0.76	0.81	0.86		0.91
<b>R-134a dx</b>					
6	1.28	1.37	1.45		1.53
7	1.07	1.15	1.23		1.31
8	0.92	0.99	1.06		1.14
9	0.80	0.87	0.93		1.01
<b>R-22 dx</b>					
6	1.28	1.34	1.40		1.45
7	1.08	1.13	1.19		1.24
8	0.92	0.97	1.03		1.08
9	0.80	0.85	0.90		0.96
<b>R-404A pumped system</b>					
6	1.00	1.07	1.13		1.19
7	0.82	0.88	0.94		1.00
8	0.70	0.75	0.80		0.85
9	0.60	0.65	0.69		0.74
<b>R-22 pumped system</b>					
6	1.13	1.21	1.28		1.34
7	0.92	0.98	1.05		1.10
8	0.76	0.82	0.88		0.93
9	0.64	0.70	0.75		0.80

Correction factors for other refrigerants, alternative fin materials, coatings and optional coil block configurations on request.

Capacities R-404A

n = 1000 rpm

Cooler model	Nominal capacity*			
	ext. press. 40 Pa		ext. press. 60 Pa	
THOR-A	kW	air flow (m <sup>3</sup> /h)	kW	air flow (m <sup>3</sup> /h)
<b>Fin spacing 4 mm</b>				
214-4-* L	5.5	2740		
216-4-* L	7.0	2710		
224-4-* L	11.0	5480		
226-4-* L	13.6	5420		
234-4-* L	16.2	8220		
236-4-* L	20.9	8140		
<b>Fin spacing 6 mm</b>				
314-6-* L	6.7	4300	6.2	3760
316-6-* L	8.7	4250	8.0	3710
324-6-* L	13.5	8610	12.4	7520
326-6-* L	17.5	8510	16.1	7430
334-6-* L	19.8	12910	18.3	11280
336-6-* L	26.8	12770	24.5	11150
414-6-* L	8.5	5550	8.2	5200
416-6-* L	11.3	5480	10.8	5140
424-6-* L	17.1	11100	16.5	10420
426-6-* L	22.6	10970	21.7	10300
434-6-* L	25.7	16650	24.8	15630
436-6-* L	33.7	16470	32.4	15450
<b>Fin spacing 7 mm</b>				
214-7-* L	4.3	2860		
216-7-* L	5.7	2820		
224-7-* L	8.6	5720		
226-7-* L	11.3	5650		
234-7-* L	12.7	8580		
236-7-* L	17.1	8480		
314-7-* L	6.2	4370	5.7	3810
316-7-* L	8.2	4320	7.5	3770
324-7-* L	12.4	8730	11.4	7620
326-7-* L	16.4	8630	15.1	7540
334-7-* L	18.3	13100	17.0	11440
336-7-* L	24.9	12950	22.8	11300
414-7-* L	7.9	5620	7.6	5280
416-7-* L	10.5	5560	10.1	5220
424-7-* L	15.8	11250	15.2	10560
426-7-* L	21.0	11130	20.2	10440
434-7-* L	23.6	16880	22.7	15840
436-7-* L	31.6	16690	30.4	15670

\* t<sub>0</sub> = -8 °C and DT<sub>1</sub> = 8 K, frosted

## Technical data

n = 1000 rpm

Cooler model THOR-A	Sound press. dB(A)	Coil surface m <sup>2</sup>	Int. vol. dm <sup>3</sup>	Cooler weight kg	Dimensions (mm)			Fans	
					length A	height B	air sock diameter	capacity kW	number
<b>Fin spacing 4 mm</b>									
214-4* L	53	46.0	12	71	1300	680	500	0.25	1
216-4* L	53	68.9	19	81	1300	680	500	0.25	1
224-4* L	56	91.9	20	112	2100	680	500	0.25	2
226-4* L	56	137.9	30	133	2100	680	500	0.25	2
234-4* L	58	137.9	28	153	2900	680	500	0.25	3
236-4* L	58	206.8	42	185	2900	680	500	0.25	3
<b>Fin spacing 6 mm</b>									
314-6* L	56	41.7	17	89	1300	880	555	0.25	1
316-6* L	56	62.5	25	102	1300	880	555	0.25	1
324-6* L	59	83.3	27	144	2100	880	555	0.25	2
326-6* L	59	125.0	40	170	2100	880	555	0.25	2
334-6* L	61	125.0	37	198	2900	880	555	0.25	3
336-6* L	61	187.5	56	238	2900	880	555	0.25	3
414-6* L	58	52.1	19	102	1500	880	730	0.45	1
416-6* L	58	78.1	29	118	1500	880	730	0.45	1
424-6* L	61	104.1	32	166	2500	880	730	0.45	2
426-6* L	61	156.2	48	199	2500	880	730	0.45	2
434-6* L	63	156.2	45	230	3500	880	730	0.45	3
436-6* L	63	234.3	67	280	3500	880	730	0.45	3
<b>Fin spacing 7 mm</b>									
214-7* L	53	27.0	12	69	1300	680	500	0.25	1
216-7* L	53	40.6	19	78	1300	680	500	0.25	1
224-7* L	56	54.1	20	108	2100	680	500	0.25	2
226-7* L	56	81.1	30	127	2100	680	500	0.25	2
234-7* L	58	81.1	28	147	2900	680	500	0.25	3
236-7* L	58	121.7	42	176	2900	680	500	0.25	3
314-7* L	56	36.1	17	88	1300	880	555	0.25	1
316-7* L	56	54.1	25	101	1300	880	555	0.25	1
324-7* L	59	72.1	27	142	2100	880	555	0.25	2
326-7* L	59	108.2	40	168	2100	880	555	0.25	2
334-7* L	61	108.2	37	196	2900	880	555	0.25	3
336-7* L	61	162.2	56	234	2900	880	555	0.25	3
414-7* L	58	45.1	19	101	1500	880	730	0.45	1
416-7* L	58	67.6	29	117	1500	880	730	0.45	1
424-7* L	61	90.1	32	164	2500	880	730	0.45	2
426-7* L	61	135.2	48	196	2500	880	730	0.45	2
434-7* L	63	135.2	45	227	3500	880	730	0.45	3
436-7* L	63	202.8	67	275	3500	880	730	0.45	3

Changes possible without prior notice



### Fans

For THOR-A coolers there is a choice of 8 different fan capacities and either 1000 or 1500 rpm fan speeds. Fans are suitable for external pressures ranging from 40 up to 120 Pa.

#### Execution

Fans are executed with balanced aluminium or polyamide fan blades, fitted with robust electrolytically galvanized and epoxy coated fan guards according to DIN 31001. Fans are mounted in vibration dampers.

Enclosed design spray-tight motors, protection class IP-55.

All motors, with the exception of the 0.18 kW, 230/50/1 motor, are equipped with a thermal safety device built in the windings, connected to separate terminals in the box.

This safety device can therefore be integrated into the control circuit. The electrical control should be arranged preferably with a manual reset device in order to prevent continuous on/off switching (tripping) of the motors. Cable inlet ranges from 7 up to 12 mm.

### Sound pressure dB(A)

Sound pressure as given in the tables are sound pressure levels in dB(A) according to EN 13487 at 5 m distance in free field conditions. Values may deviate depending on situations at site. The table below gives calculated sound pressure corrections at various distances.

Distance m	Correction dB(A)
1	+ 14
2	+ 8
3	+ 4
4	+ 2
5	0
10	- 6
20	-12
50	-20

### Fans 50 Hz

Fan motor W	Motor voltage* V	Electric capacity		Adj. value overloadrelays		cable inlet
		nom. kW	abs. kW***	0 °C	A -20 °C	
<b>Fan motors n = 1000 rpm</b>						
250	230/400/3	0.25	0.33	1.2	1.3	2 x M20x1.5
180	230/1**	0.18	0.35	2.4	2.5	2 x M20x1.5
450	230/400/3	0.45	0.45	2.0	2.1	2 x M20x1.5
<b>Fan motors n = 1500 rpm</b>						
250	230/400/3	0.25	0.37	1.1	1.1	2 x M20x1.5
220	230/1	0.22	0.37	2.6	2.8	2 x M20x1.5
550	230/400/3	0.55	0.70	1.7	1.8	2 x M20x1.5
550	230/1	0.55	0.70	5.5	6.0	2 x M20x1.5
1200	230/400/3	1.20	1.20	3.0	3.2	2 x M20x1.5

\* Motor windings 230 Volt.

\*\* These 230/50/1 motors are suitable for temperatures down to -20 °C and are not provided with a thermal safety device in the windings.

\*\*\* Absorbed fan motor energy is measured in under laboratory conditions at ambient temperature 20 °C. These values may vary depending on local conditions.





Dimensions

Cooler model	Dimensions (mm)									
THOR-A	A	B	C1	C2	D1	D2	E	F	G	H
11*	1320	580	800		660		450	450	260	
12*	2120	580	1600		1060		450	450	260	800
13*	2920	580	2400		1460		450	450	260	800
21*	1320	680	800		660		450	500	310	
22*	2120	680	1600		1060		450	500	310	800
23*	2920	680	2400		1460		450	500	310	800
31*	1320	880	800		660		500	555	410	
32*	2120	880	1600		1060		500	555	410	800
33*	2920	880	2400		1460		500	555	410	800
41*	1520	880	1000		760		600	730	410	
42*	2520	880	2000		1260		600	730	410	1000
43*	3520	880	1000	2000	1010	1500	600	730	410	1000

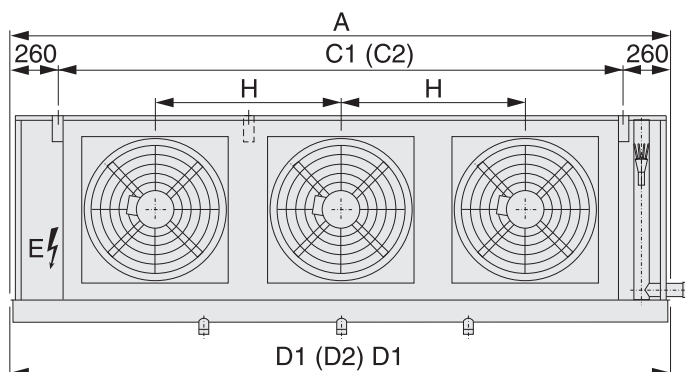
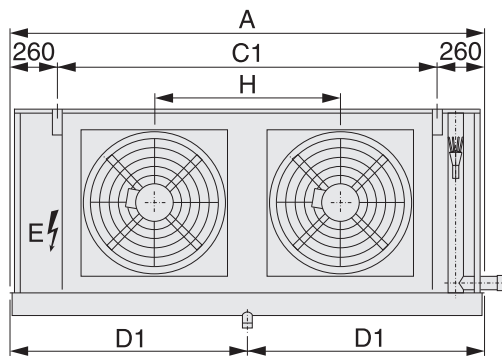
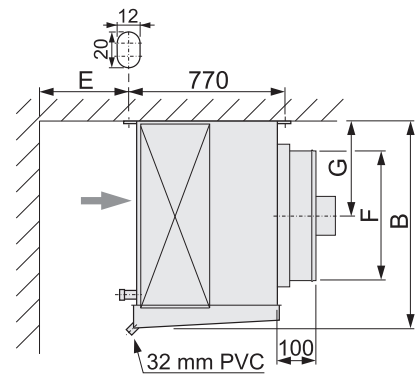
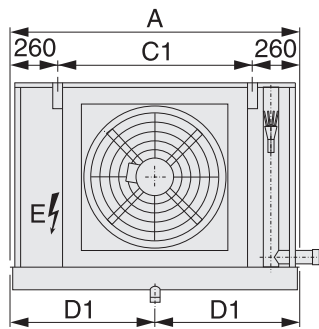

Changes possible without prior notice

### **Alfa Laval in brief**

Alfa Laval is a leading global provider of specialized products and engineered solutions.

Our equipment, systems and services are dedicated to helping customers to optimize the performance of their processes. Time and time again.

We help our customers to heat, cool, separate and transport products such as oil, water, chemicals, beverages, foodstuffs, starch and pharmaceuticals.

Our worldwide organization works closely with customers in almost 100 countries to help them stay ahead.

### **How to contact Alfa Laval**

Up-to-date Alfa Laval contact details for all countries are always available on our website at [www.alfalaval.com](http://www.alfalaval.com)